

MEHVAR SAZAN CHICHEST Co.

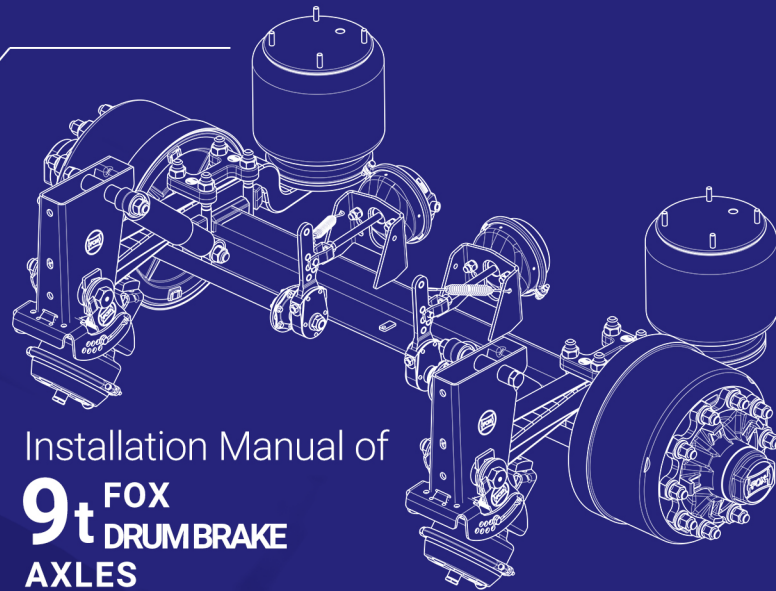

Installation Manual of
9t FOX
DRUMBRAKE
AXLES

WWW.FOXCH.COM



CHICHEST AXLE MANUFACTURING Co.

WWW.FOXCH.COM



Installation instruction of 3x9 Ton Fox 140mm Drum Brake Axle

Certificate code

Mehvar Sazan Chichest Company

10 km of Mahabad road, Urmia, Iran

Tel: 41 18 38 33 044

Fax: 57 18 38 33 044

Website: www.foxch.com

Email: info@foxch.com

Social Networks:

Instagram: [fox.msc](https://www.instagram.com/fox.msc)

Facebook: [fox.msc](https://www.facebook.com/fox.msc)

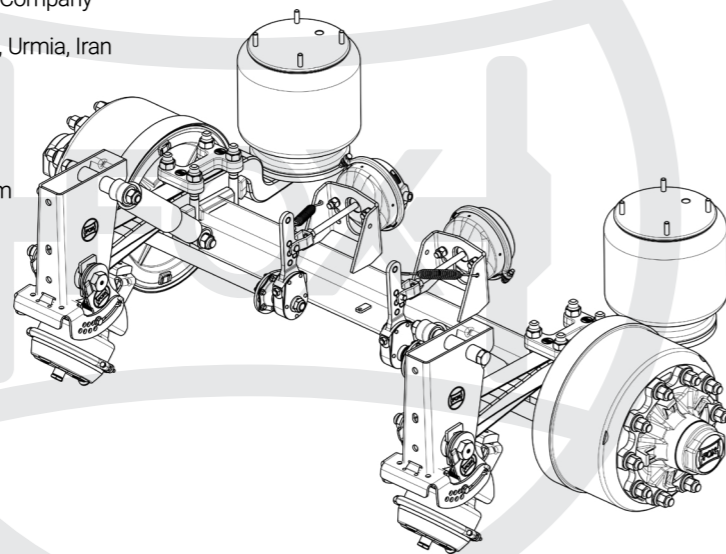

Contents

Introduction	6
Technical specifications of the trailer of the 9 ton FOX Drum trailer	10
Axle beam	11
Suspension System	11
Rubber Bush Assembly	12
Replacment of hanger bracket bolt	12
Hub Unit	13
Technical specifications of accessories	14
Brake boosters	15
Mounting of 3x9 ton Drum axle on trailer	15
Air Bag assembly	16
Axle assembly	16
Conventional adjustment of a tri- axle set	16
Axle Lift Assembly	17
Controls and inspections	17
Regular services	18
Calculating the cost and issue of warranty services	19
Contact	19

Introduction

Today, one of the basics of competition in organizations is customer orientation and customer satisfaction, because the main driver in commercial and service organizations that seek major improvements in their development path are the customers of those organizations. The great efforts made today by researchers, experts, and managers of commercial organizations to improve performance management tools and develop a customer-oriented attitude show that customer satisfaction is now one of the most important factors in determining the success of organizations in business and profitability. Customers who are more satisfied with the organization express their positive experiences to others and thus become a means of advertising for the organization, which in turn, reduces the cost of attracting new customers. This is especially important for professional service providers, as their reputation is a key source of information for new customers.

In this regard, the management of Mehvar Sazan Chichest Company, using machines and quality and advanced engineered production equipment and raw materials in accordance with world standards as well as human resources experts, has done concrete measures that increase customer satisfaction of Mehvar Sazan Chichest Company, over more than a decade of its activities in the field of design and production of trailer axles and trailer parts.

One of the measures taken to increase customer satisfaction of Mehvar Sazan Chichest Company is to prepare and compile an installation guide for the company's products, which, while facilitating the installation and commissioning of the product, avoids possible mistakes and unwanted human errors in installing products, in particular, the company's production axles, and will lead to better product efficiency; In addition, possible future

defects of the product in case of correct and standard installation, will be within the framework of product warranty, and after-sales services of the company's products.

In the following text, which has been prepared and compiled with the efforts of sales engineering and after-sales services of Mehvar Sazan Chichest Company and Maral Industrial Group, it is tried to give a complete description for the method of selecting the axle, delivery of the triple set and axial spare parts, preparation of the triple-axles set for assembly, step by step assembly of the first axle, second axle, and third axle, how to make the necessary controls for axle installation and finally, the installation of the axle lift set on the first axle.

Welcome to the world of FOX trailer parts and axles, and it is recommended that you read this manual before driving, which includes specific safety information and pre-driving warnings. FOX Company is constantly adapting the axles of its produced trailers and components and parts in accordance with the latest safety and technological standards, as well as the correct installation of parts and equipment. Please keep this guide with the vehicle and keep a copy of this guide if different drivers use the trailer and provide a copy of this guide to the buyer if ownership is transferred.

Have a safe trip

Quality Control Department & Sales engineering and after-sales service unit of Mehvar Sazan Company

www.foxch.com

This instruction has been prepared as an installation, repair and maintenance guide and can be used by drivers, trailer users and after-sales service representatives.

Please obtain instructions from the company before handing over the product when driving the product. It is recommended that drivers and users of the product read all of the following instructions and then start driving. Pay attention to the allowable load capacity of the axle in accordance with the manufacturer's delivery instructions.

Do not perform welding, cutting, or any additional operations on the fox axles. If you replace the bolt and nut of the axle to replace it, you need to close it with the amount of torque specified in the instructions.

Ride Height adjustment: There is a risk of falling during the height adjustment process. Before driving with the trailer, make sure that the driving height of the axle is adjusted properly.

Suspension system: Capability of the suspension system, which includes the Air bag and the Air bag piston, and the bottom plate which are constantly under pressure and tension. This mode greatly reduces the damage caused by a sudden impact on the axle. In case of imbalance in driving or loss of bolt connection, contact an authorized repair shop and continue driving after receiving instructions. The consumer must take the necessary measures in a timely manner in accordance with the maintenance instructions.

Braking system: During the braking process, friction generates heat, which can cause burn injuries if the hand or part of the body comes in contact without protection. Technical defects in the brake system and reduced braking power increase the risk of accidents, so carry out periodic repairs and maintenance by authorized repair shops. FOX axle parts are of high quality and this is a factor in high driving safety. The use of non-standard parts increases the risk of accidents while driving.

Recommendations: Use the original parts recommended by the manufacturer. Ask authorized repair shops for parts supply and replacement services.





Technical specifications of the FOX 9-ton 140mm Drum brake axle:

To select and purchase the axle for the trailer, special attention should be paid to the following important product specifications:

FOX 9-ton 140mm Drum brake axle		Product Code: 08.000.000	
Permitted axle load	9000 Kg	Tyre Fitment	Single Tyre
Tyre Example (mm)	385 / 65 R22.5	Suspension Center	1300 mm
Track Width	2040 mm	Wheel Stud/connection	10 x M 22X1.5/ 280 - 335
Trailing arm	100 mm	Offset (mm)	0 mm
Caliper	-	Brake	Drum
Exciter(ABS) ring	OK	Bearing	SKF - 33213 / 33118
Air Bag	8813	Axle Cross Section	140sq X 12mm
Axle Weight (with Axle lift)	570 Kg	Axle Weight(without Axle lift)	554 Kg

- **Permitted axle load:** is related to the allowable capacity of each axle
- **Tire Example:** Represents a conventional tire that will be fastened to the axle
- **Track Width:** Indicates the distance from the center to the center of the tire
- **Trailing arm:** Indicates the width of the axle spring, and in axle, instead of the spring, set is used.
- **Exciter (ABS) ring:** Indicates whether the axle has an ABS ring or not
- **Air Bag:** Indicates the characteristics of the air bag used in the axles
- **Tire fitment:** Indicates the number of tires used on each side of the axle. (Single or twin-tire axles)
- **Suspension Center:** Represents the center to the center of the trailing arm.
- **Wheel Stud/connection:** Indicates the specifications of the wheel screw and the fitments
- **Offset:** Indicates the distance from the center of the tire to the inner surface of the wheel rim that is attached to the hub
- **Brake:** Indicates the type of brake system of the axle (Drum or Disc)
- **Bearing:** Indicates the specifications of the bearings used inside the ball
- **Bearing:** Indicates the specifications of the roller bearings used inside the hub
- **Axle Cross Section:** Indicates the dimensions of the cross-section of the Axle beam
- **Axle Weight with Axle lift:** Indicates the weight of an axle with an axle lift.
- **Axle Weight without Axle lift:** Indicates the weight of an axle without an axle lift.

Axle beam set:

Fox axle beams are produced by robotic welding automatically. After that, two sides of simultaneously by special axle stub journals are grinded in order to reach the high precision tolerances and this capability thus leads to a direct effect in reducing the maintenance costs of the axle, including bearings, brake pads, tires wear,, and the axle life.



Suspension Set:

The Hanger Brackets, must be installed and welded on the trailer chassis in its exact position. Since the basis of the mountings of the axle is the hanger brackets, it is very important that, these parts shall be installed and welded in its exact position without any disortion.

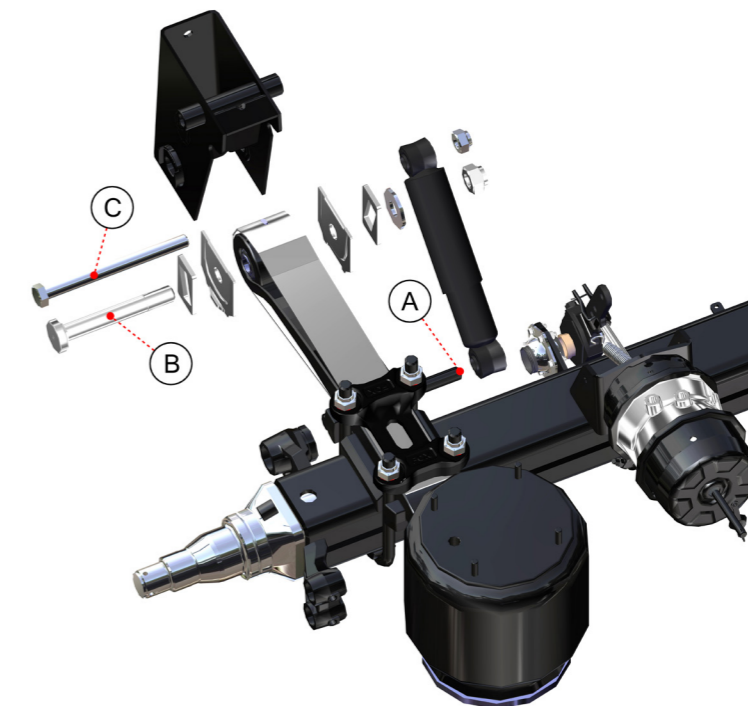

Characteristic of the screws torque		
A	M20x1.5-L130	400Nm
B	M30x3.5-L215	400Nm+180°
C	M20X1.5-L170	400Nm

Spring assembly:

To install the springs on the Axle Beam, first, we place the left or right spring seats in its position in relation to the axial side, insert the axle U-Bolts from below and place the segment U-Bolt between the U-Bolt and the Axle Beam and place the Z-spring on the spring seats and install the spring plate on it as well.

Note: tighten nuts to the prescribed torque in several stages on the alternate sides.

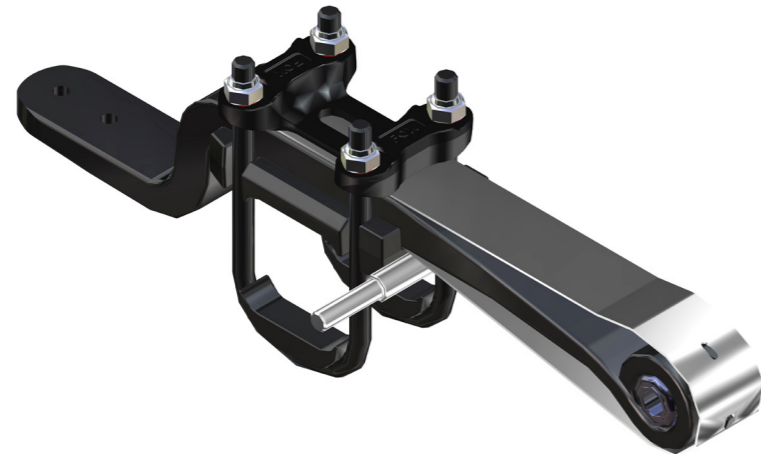

Replacement of Hangerr Bracket bolt:

To replace the Hanger Bracket screw, loosen the hexagon head lock nut M30 x 3.5- / SW = 46m with a wrench number 46 and replace the Hanger Bracket bolt. To do this, make sure to use authorized repair shops. The allowable torque for it is 400Nm + 120°±10°.



Hub Unit:

One of the parts is the hub unit, which is shown separately in the following figure with its accessories:

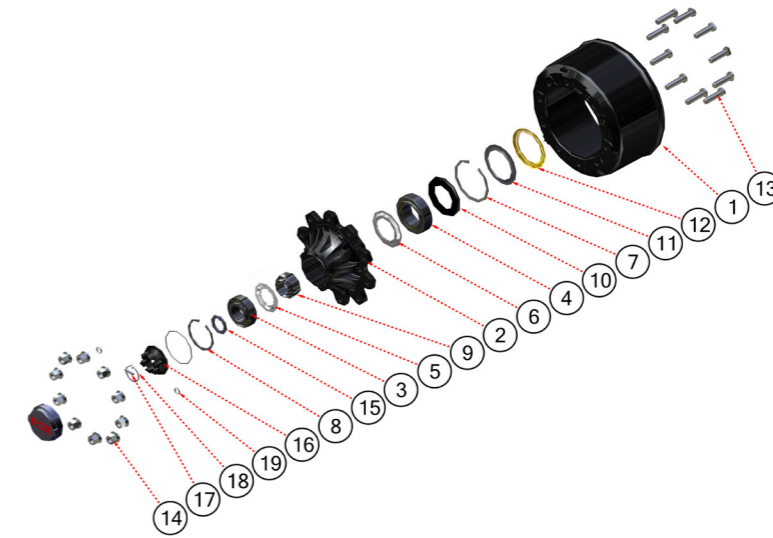

Row	Title of the piece	Quantity	Technical characteristics	Technical code
1	Brake Drum	1	Casting piece	03.201.202
2	Axle Hub	1	Casting piece	03.201.203
3	Small roller bearing	1	SKF tapered roller bearing with code 33213	01.201.203
4	Big roller bearing	1	Bearing with code 33318	01.201.204
5	Small metal duster	1	Galvanized sheet 0.5 mm	01.201.205
6	Big metal duster	1	Galvanized sheet 0.5 mm	01.201.206
7	Circlip	1	Ø169xØ148 internal thorn Spring	01.201.207
8	Circlip	1	Ø129xØ115 internal thorn Spring	01.201.208
9	Grease cartridge	1	Plastic piece	01.201.209
10	Oil Seal	1	Standard Seal	01.201.210
11	Plastic duster	1	Plastic piece	01.201.211
12	ABS ring	1	-	01.201.212
13	Wheel screws	10	Round head flat end screw M22x1.5-L80	01.201.213
14	Wheel nuts	10	M22x1.5 hexagon nut	01.201.214
15	Adjusting washer	1	Structural Steel	01.201.215
16	Axle nut	1	Forged piece	01.201.216
17	Split Pin	1	Shaft	01.201.217.01
18	Split Pin	1	Ring Spill with 2.5 mm profile diameter	01.201.217.02
19	Wheel bolt rim	2	D12.5X11X6	01.201.218

Technical specifications of axle accessories:

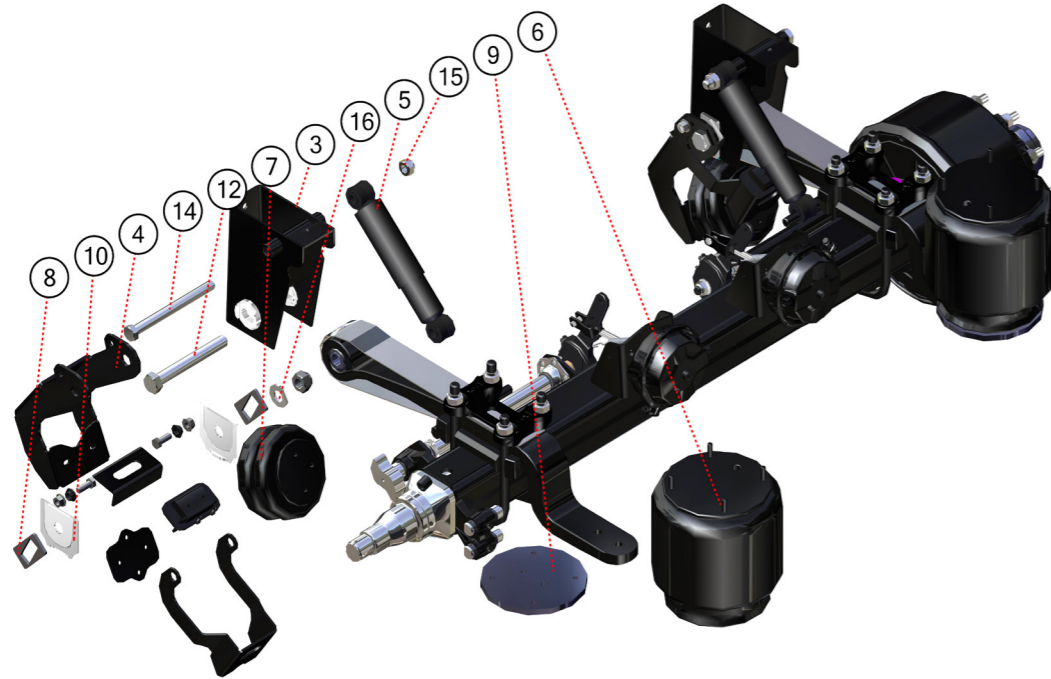

Row	Product	Quantity	Technical code
1	Set of axles without axle lift	2	08.000.101
2	Set of axles with axle lift	1	08.000.201
3	10 cm Hanger Bracket	6	01.303.301
4	10 Cm Spring Liftging Set Type 1	2	08.801.000
5	Shock absorber	6	01.401.407
6	Airbag	6	02.401.405
7	Convolute air spring	2	04.501.507
8	Adjustment washer	12	01.301.311
9	Air Bag bottom sheet	2	02.101.117
10	Sliding adjustment Square washer	12	01.301.312
11	Hexagon Hanger Bracket head screw	2	01.301.305
12	Hanger Bracket round head Screw	4	04.301.320
13	Hexagon lock nut	6	01.301.306
14	shock absorber connection screw	6	08.301.307
15	Spring Bolt	12	01.301.308
16	washer	6	01.301.321

Boosters:

In each set of axles, T30 boosters are used in the first axle, and in the next axles, T30 / 30 boosters are used.



Row	Set title	FOX technical code	Supplier technical code
1	Single brake booster T30	02.101.107	ARFESAN 01.63.00.07
2	Double brake booster T30 / 30	02.101.118	ARFESAN. 03.24.00.39

Torque of the booster nuts	
T30	180Nm
30/T30	180Nm

Mounting of 3x9 ton Drum axle on trailer:

The order of installation of the triple-axle set: It is in such a way that the first axle is assembled with the lifting set and the rest respectively.

Meanwhile, the axle, which has an ABS sensor, is assembled and installed in the middle axle.

Shock Absorber Assembly: According to the figure below, place a number of shock absorbers in the correct position and insert the screw in the specified direction and then tighten the nut in a clockwise direction.

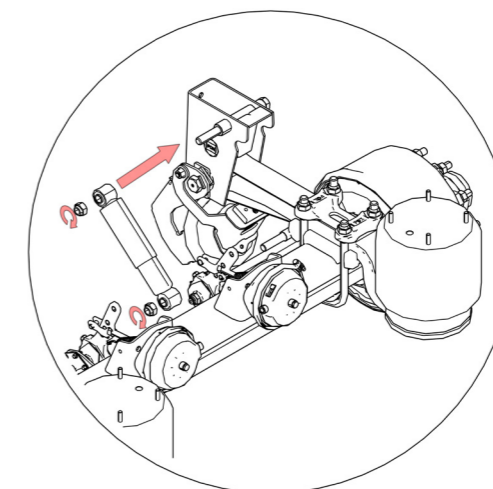

Air Bag assembly:

Insert the screw under the Air Bag in the specified location on the Spring and tighten the nut.

Note: During the assembly of the Air Bag, make sure that air inlet is placed in the centre side of axle.



Axle assembly:

We put the axles in their specified positions and tighten the nut.

Conventional adjustment of a tri-axle set:

This part of the axle assembly is of special importance, the accuracy in adjusting the wheelbase is directly related to the correct operation of the axle under the trailer. To do this, according to the figure below, using a tape measure, we measure the distance from kingpin to the center of the second axle from one side, and the amount obtained from the tape measure, whatever it is, on the other side of the axle should show the same size. Otherwise, adjust the size by sliding the axle forward or backward in the washer. If the size of the bolt is the same (M30X3.5), we tighten the Hanger Bracket completely with a wrench. Next, adjust the distance of the first axle to the second axle with the tolerance value specified in the figure below, and in the same way, tighten the Hanger Bracket (M30X3.5) completely with a wrench. Finally, the distance between the third axle and the second axle with the tolerance specified in the figure below is measured, and in the same way, tighten the Hanger Bracket

(M30X3.5) completely with a wrench. The allowable tolerance to the left of the second axle relative to the right of the second axle in the distance from the kingpin to the center of the second axle is $\pm 2\text{mm}$ and the allowable tolerance from the center to the center of the first axle relative to the second axle is $\pm 1\text{mm}$. Also, the allowable tolerance of the center to the center of the third axle compared to the second axle is $\pm 1\text{mm}$. This requires more care in adjusting the axle as it affects the life of the axle and the axle tire wear.

Title	Acceptance limit
Permissible tolerance of the kingpin to the center of the second axle	$\pm 2\text{mm}$
Permissible tolerance of the center to the center of the first axle relative to the second axle	$\pm 1\text{mm}$
Permissible tolerance from center to center of the third axle relative to the second axle	$\pm 1\text{mm}$

Fig A

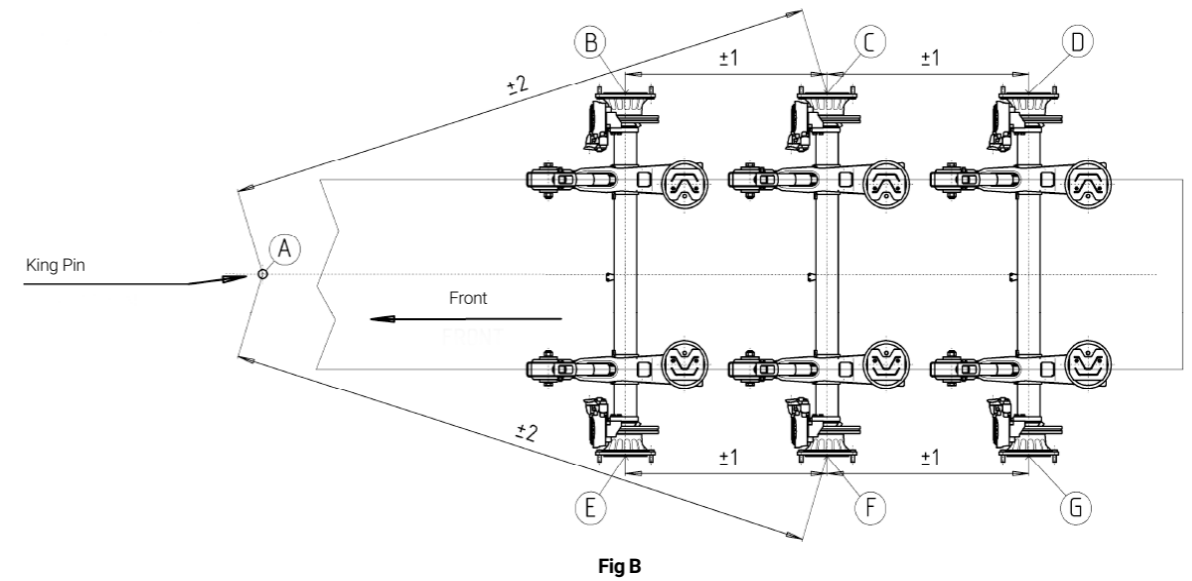

Mounting of axle lift:

Axle lift should be installed on the first axle to have lifting capability. To install the axle lift, open the sticker on the convoluted air spring inlet and place it on the axle lift in its seat from the same wind inlet and fasten it with two screws (hex screw with hexagonal washer 30-M10X1.5). A 14-point flat wrench is used to fasten both screws.

Note: During the assembly of the convoluted air spring, make sure that the air inlet is facing downwards.

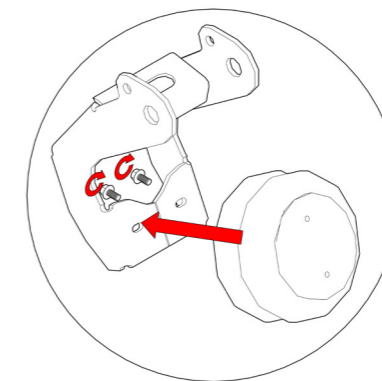

To install the movable arm of the lifting set, place it on the convoluted air spring from the opposite side and use two bolts (hexagon head bolts M10x1.530-) with 2 washers in place and close it by hand and connect it with the moving part by two screws (hexagon head screw M16x2 - 40mm) with two nuts (hexagon nut and washer M16x2).

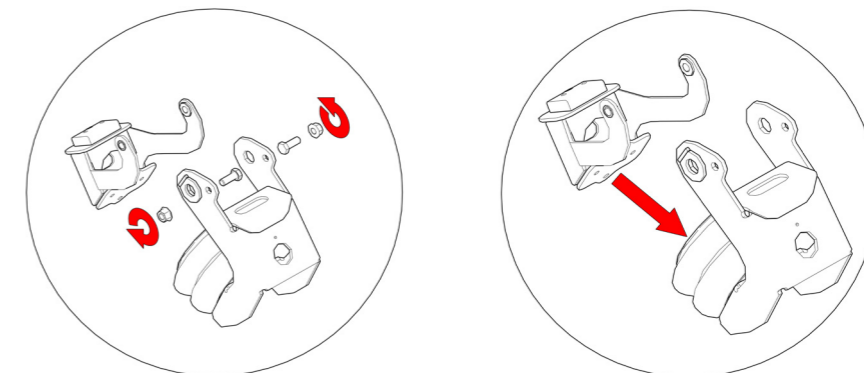

Then assemble the other parts of the lifting set when installing on the axle in the order shown in the figure below.

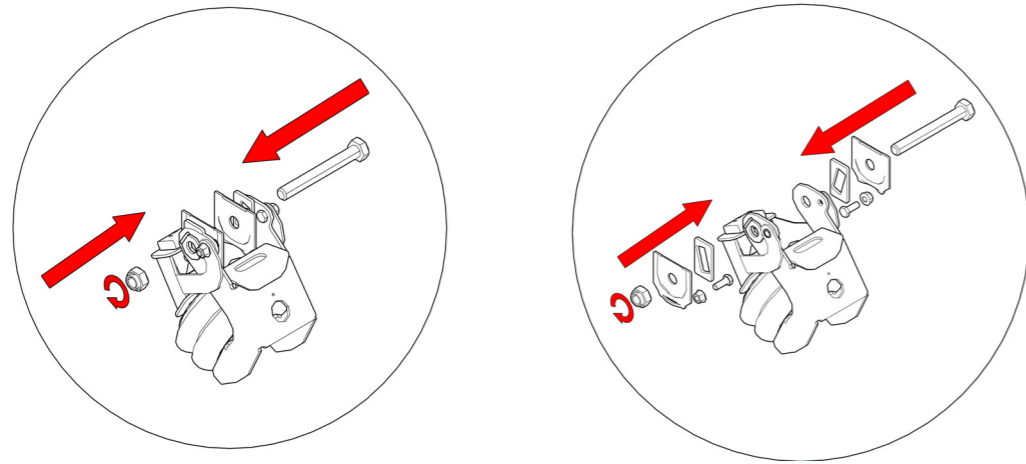

Then insert the set screw (position 1 shown in the figure below) (which was mounted on the convoluted air spring) from the bottom of its hole and insert the set screw nut connecting the convoluted air spring (M10x1.5 seal nut) and tighten it with 17-point box wrench from the inside of the hanger bracket, Also, insert the bolt connecting the convoluted air spring to the hanger bracket in the same hanger bracket (position number 1 shown in the figure below) by hand and tighten it completely with a 17-point box wrench.

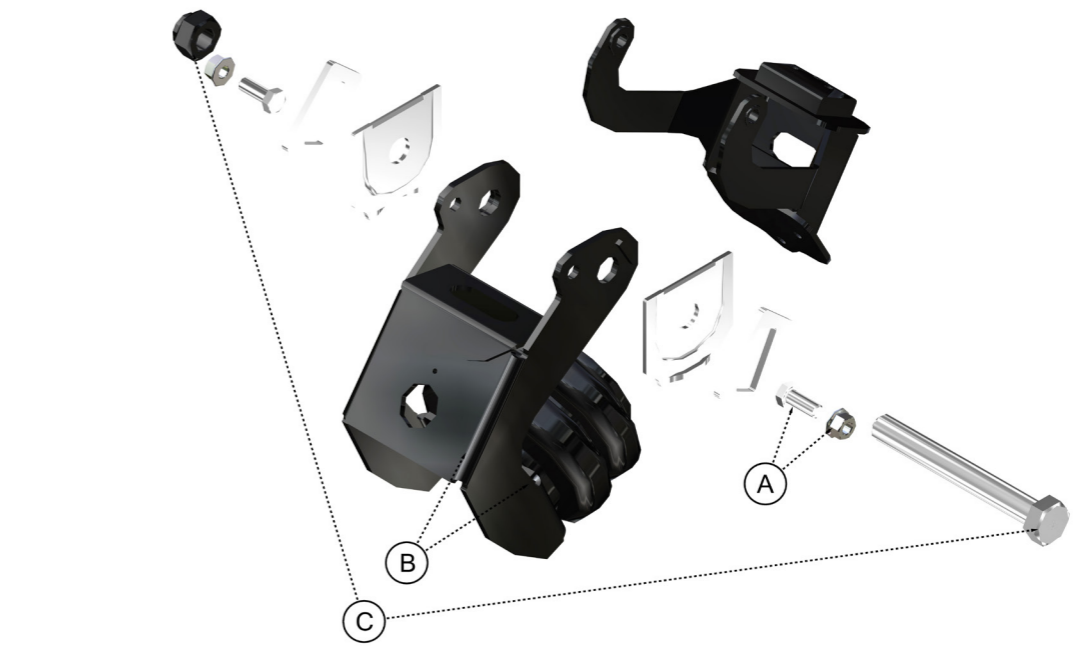
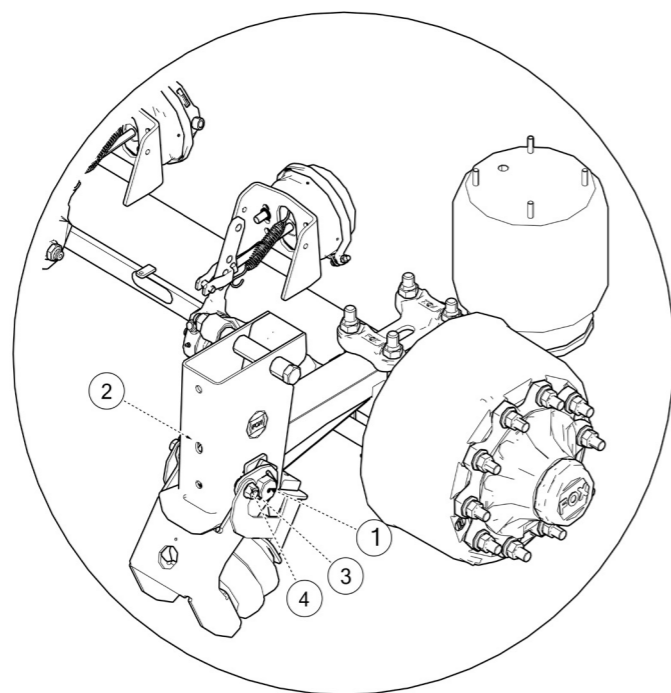

Characteristic and Torque of Screws		
A	M16×2 - 40	70Nm
B	M10X1.5 - 20	30Nm
C	M30×3.5 - 235	400Nm

Controls and inspetions:

Controls and inspections according to the manufacturer's recommendations increase the reliability and durability of the axles and prevent unwanted defects.

- Controls and inspetions in authorized agencies are mandatory and failure to do so will result in the cancellation of the warranty.

Periodic Visits and Controls				
Check or control title	10000Km	7000Km	5000Km	2000Km
Control offastenings of axle	*	*		*
Check the axle lift function	*	*		*
Check the shock absorbers and afstenings of the shock absorbers	*			*
Check hubs and tire wear control	*	*	*	*
Check brake system performance	*			*
ABS function control	*			
Check air bags		*		*



Regular Services:

Performing regular services as recommended by the manufacturer increases the reliability and durability of the axles and prevents unwanted defects.

- Perform regular services at authorized agencies, otherwise the warranty would be regarded as invalidate.

Instructions for maintaining the drum axle					
Repair and maintenance intervals		Periodic visits			
Whichever comes first	Mileage distances	After the first 2000 km	Every 10000 km	Every 30000 km	Every 75000 km
	Time intervals	After the first month	Once every 1 month	Once every 3 month	Once every 6month
Visual inspection and safety					
Optional maintenance on hub unit. Visual inspection for grease		*	*	*	*
Check the brake caliper guide system. Check for free movement and sliding function.		*			*
Check dust-proof rubber covers for cracks and damage. Check the adjustment cap for proper seating.		*			*
Check brake pad thickness at regular intervals (for example, whenever you adjust the tire pressure) but finally every 3 months		*	*		
Check the brake drum for cracks.		*		*	
Annual general inspection (including: brake system, Air Bag ⚠, tires, etc.)		*			*
Annual general safety inspection (including: trailer and ABS brake compatibility, etc.)		*			*
Mechanical inspection					
Note: Make sure that the wheel nuts are tight according to the specified torque after the first 50 and 150 km. (After each opening and closing of the wheels)					
Special service conditions					
Vehicles with long stopping periods		Service at specified intervals			
Vehicles used in severe conditions		Reduce the service distance to 3 months or 30,000 km			
Note: For receiving any services in the warranty period and after it, and also for performing Regular services, refer to the authorized after-sales service agencies of Mehvar Sazan Chichest Company. Also, provide the required spare parts that are approved by the company from the authorized dealerships after the sale, the list of which is as follows.					

Calculate the cost and bill the warranty service:

Transportation, repair fees, and parts costs if the repairs are covered by the warranty (in accordance with the terms of the warranty service) will be done at the expense of the company and otherwise it is on the customer. After completing the service, you will be provided with an invoice for the actions taken by the after-sales service representative. Please check the items in it and sign if approved.

After Sale Services Representatives					
Row	Representative	City	Phone	Cell	Representative address
1	Hosseinkhah	Tehran	021 - 56391493 -5	09143896067	In front of Nasirabad , before Robot Karim, after Adran intersection, Tehran
2	Naseri	Orumieh	044 - 32417522	09141417371	Truckers' alley, Salmas Road, Urmia
3	Alipour	Garmeh	058 - 32500278	09155840889	In front of Jalaluddin Castle, Imam Reza Boulevard, Garmeh, North Khorasan
4	Niki	Mashhad	051 - 33924700	09151163494	Towards the cargo terminal, Karafarin Square, Mashhad
5	Jafari	Shiraz	071 - 37218037	09171284464	After Tarehbar, after the southern third, Velayat Boulevard, Persian Gulf Boulevard, Shiraz
6	Khazaie	Nahavand	021 - 55289867	09181519099	Km 3 of Kermanshah road, Nahavand
7	Pasian	Ghare Ziaodin	044 - 36728458	09141630150	Truck owners, entrance to the city, Qarah Zia al-Din
9	Mohammadi	Esfahan	031 - 33870401	09128910469	Corner of Maharat street , Shahr-dari square, Amir kabir town, Isfahan
10	Asgarpour	Kerman	034 - 33241088	09131409134	Before Imam Reza Belt, Saadat Abad, Tehran Road, Kerman
11	Rezaei	Bojnourd	058 - 32236754	09153858329	Next to Seyed Jamaluddin Asadabadi Conservatory, Tehran Road, Bojnourd
12	Akbari	Marand	041 - 32220210	09148149936	In front of Iran Khodro Mahdiloui branch, Bazargan Road, Marand
14	Kosropanah	Sirjan	034 - 42255019	09131454633	In front of Khoshoei truck parking lot, belt, Sirjan
15	Zojaji	Ardabil	045 - 33814288	09148201791	Before Radio and TV, Jaam e Jam Street, Ardabil
16	Karimi	Yazd	035 - 35275894 - 5	09131518520	After Al-Ghadir Zarch square, 13 km of Yazd-Tehran road, Yazd
17	Ghaderi	Taybad	-	09151264743	Eastern Belt, Taybad

Exploded view diagram of a 9-ton FOX Drum Brake Axle



MARAL
HOLDING

QUALITY IS IN OUR SOUL.
MARAL HOLDING



MARAL
HOLDING